

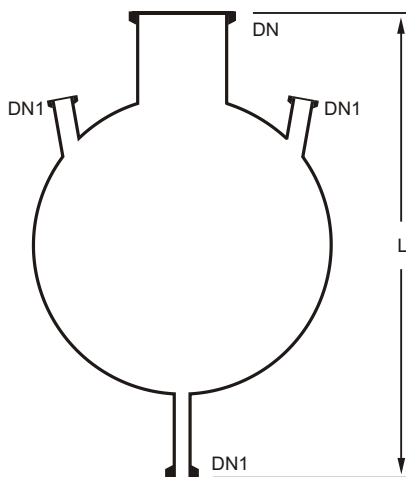

## VESSELS & STIRRERS

Vessels are used as reactors, receivers, separators, measuring, feeds etc. Vessels can be used under full vacuum and as per given below working pressure (Bar g).

Vessels are available in spherical / cylindrical shape from 5Ltr. to 300Ltr. capacity. Vessels are provided with a bottom outlet nozzle, for which a suitable valve can be chosen from range of valves.

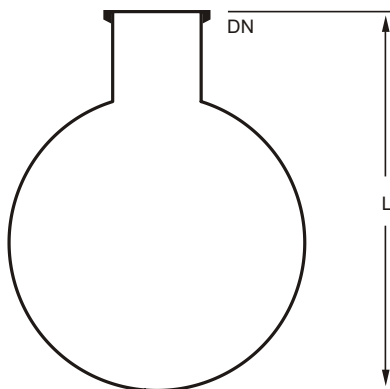
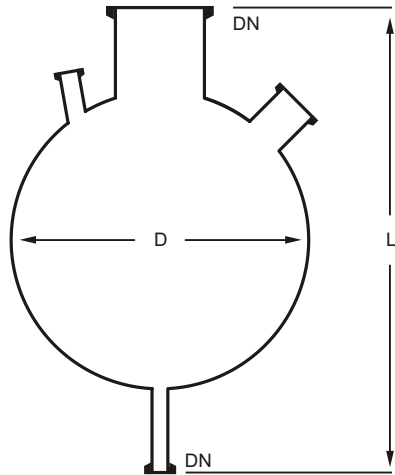

### SPHERICAL VESSELS GENERAL DATA

NOMINAL CAP. (LTR.)	BULB DIAMETER MM D	MAXIMUM INTERNAL PRESSURE (Bar g)	TOLERANCE OF DIAMETER MM	TOLERANCE IN LENGTH MM L
5	220	1.0	± 2	± 5
10	285	0.8	± 2	± 5
20	350	0.7	± 2	± 5
50	470	0.5	± 3	± 5
100	600	0.4	± 4	± 5
200	750	0.25	± 5	± 8
300	850	0.20	± 6	± 8

500 liter Vessel on request.

### SINGLE NECK SPHERICAL VESSELS

NOMINAL CAP. (LTR.)	DN MM	L MM	CAT REF.
5 L	40	270	SVSA 5
10 L	40	350	SVSA 10
20 L	80	430	SVSA 20
50 L	100	590	SVSA 50
100 L	150	740	SVSA 100
200 L	225	910	SVSA 200
300 L	300	1025	SVSA 300

Tolerance ± as per given general data in vessel chapter.

### THREE NECK BOTTOM OUTLET SPHERICAL VESSELS

NOMINAL CAP. (LTR.)	DN	DN1	L	CAT REF.
5 L	40	25	345	SVSM 5
10 L	40	25	425	SVSM 10
20 L	80	25	525	SVSM 20
50 L	100	40	690	SVSM 50
100 L	150	40	840	SVSM 100
200 L	225	40	1020	SVSM 200
300 L	300	40	1155	SVSM 300

Tolerance ± as per given general data in vessel chapter.

#### FOUR NECK BOTTOM OUTLET SPHERICAL VESSELS

NOMINAL CAP. (LTR.)	DN	DN1	DN2	L	CAT. REF.
5 L	50	25	40	445	SVSPL 5
10 L	50	25	40	525	SVSPL 10
20 L	80	25	40	605	SVSPL 20
50 L	100	40	100	765	SVSPL 50
100 L	150	40	100	920	SVSPL 100
200 L	225	40	100	1100	SVSPL 200
300 L	300	40	100	1215	SVSPL 300

Tolerance  $\pm$  as per given general data in vessel chapter.

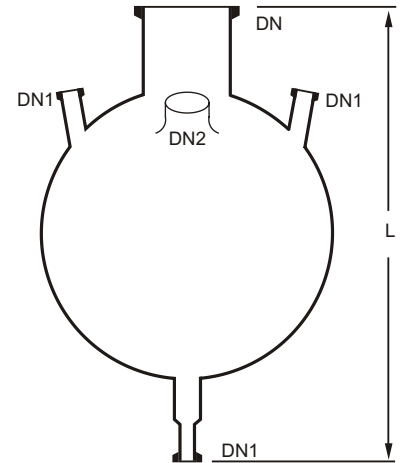

#### FIVE NECK BOTTOM OUTLET SPHERICAL VESSELS

NOMINAL CAP. (LTR.)	DN	DN1	DN2	L	CAT. REF.
5 L	50	25	40	445	SVSL5
10 L	50	25	40	525	SVSL10
20 L	80	25	40	605	SVSL20
50 L	100	40	100	765	SVSL50
100 L	150	40	100	920	SVSL100
200 L	225	40	100	1100	SVSL200
300 L	300	40	100	1215	SVSL300

Tolerance  $\pm$  as per given general data in vessel chapter.

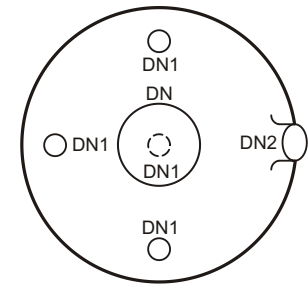

#### FIVE NECK BOTTOM OUTLET SPHERICAL VESSELS

NOMINAL CAP. (LTR.)	DN	DN1	DN2	L	CAT. REF.
5 L	50	25	40	445	SVS 5
10 L	50	25	40	525	SVS 10
20 L	80	25	40	605	SVS 20
50 L	100	40	100	765	SVS 50
100 L	150	40	100	920	SVS 100
200 L	225	40	100	1100	SVS 200
300 L	300	40	100	1215	SVS 300

Tolerance  $\pm$  as per given general data in vessel chapter.

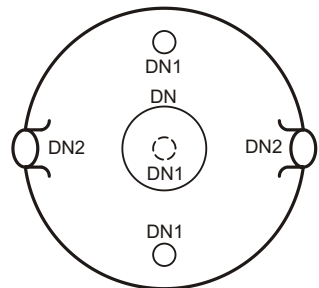

## SPHERICAL VESSELS WITH NOZZLE AT 90°

These vessels are used in circulatory boiler system. More nozzles can be provided on the equator on request .

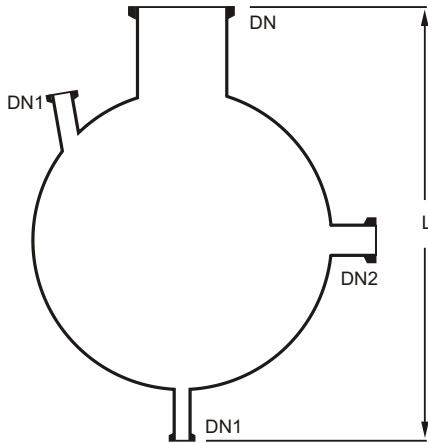

NOMINAL CAP. (LTR.)	DN	DN1	DN2	L	CAT. REF.
5 L	40	25	25	345	SVSD 5
10 L	40	25	40	425	SVSD 10
20 L	80	25	40	525	SVSD 20
50 L	100	40	80	690	SVSD 50
100 L	150	40	80	840	SVSD 100
200 L	225	40	80	1020	SVSD 200
300 L	300	40	80	1155	SVSD 300

Tolerance ± as per given general data in vessel chapter.

## RECEIVERS SPHERICAL VESSELS

Receivers are provided with built-in drip pipe.

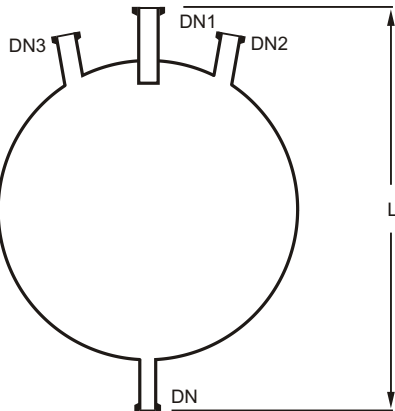

NOMINAL CAP. (LTR.)	DN	DN1	DN2 10 DEG.	DN3 10 DEG.	L	CAT. REF.
5 L	25	25	25	-	345	SVR 5
10 L	25	25	25	-	425	SVR 10
20 L	25	25	25	-	525	SVR 20
5 L	25	25	25	25	345	SVRB 5
10 L	25	25	25	25	425	SVRB 10
20 L	25	25	25	25	525	SVRB 20

Tolerance ± as per given general data in vessel chapter.

## ADDITION SPHERICAL VESSELS

These vessels are provided with a short bottom outlet. It should be supported on a vessel holder/ holding ring.

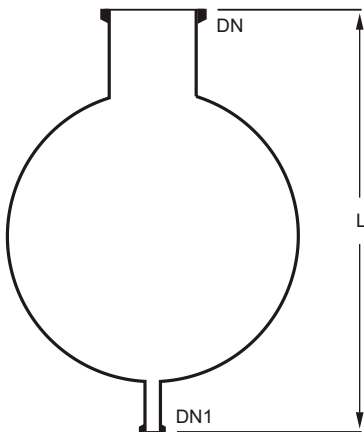

NOMINAL CAP. (LTR.)	DN	DN1	L	CAT REF.
5 L	40	25	345	SVA 5
10 L	40	25	425	SVA 10
20 L	80	25	525	SVA 20
50 L	100	40	690	SVA 50
100 L	150	40	840	SVA 100
200 L	225	40	1020	SVA 200
300 L	300	40	1155	SVA 300

Tolerance ± as per given general data in vessel chapter.

## WIDE BOTTOM OUTLET SPHERICAL VESSELS

These vessels are used to fit immersion heat exchangers in the bottom.

NOMINAL CAP. (LTR.)	DN	DN1	DN2	DN3	L	CAT REF.
50 L	100	150	40	100	715	SVSR 50
100 L	150	150	40	100	885	SVSR 100
200 L	225	150	40	100	1075	SVSR 200
50 L	100	150	40	100	725	SVSE 50
100 L	150	225	40	100	900	SVSE 100
200 L	225	225	40	100	1100	SVSE 200

Tolerance  $\pm$  as per given general data in vessel chapter.

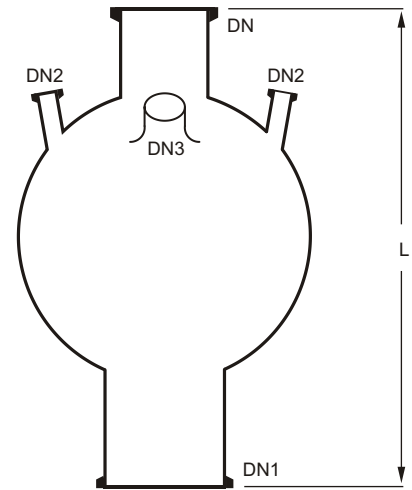

## CYLINDRICAL VESSELS

Cylindrical vessels can be used for various purposes e.g. reaction, separating receiver and feeding. 50 liter and above cylindrical vessel need to be supported in a vessel holder.

NOMINAL CAP. (LTR.)	DN	DN1	L	L1	CAT REF.
5 L	100	25	700	60	SVZ 5/4
5 L	150	25	460	60	SVZ 5/6
10 L	150	25	720	60	SVZ 10/6
20 L	225	25	750	60	SVZ 20/12
30 L	300	40	635	65	SVZ 30/12
50 L	300	40	915	65	SVZ 50/12
100 L	450	40	890	65	SVZ 100/18
150 L	450	40	1195	65	SVZ 150/18
200 L	450	40	1500	65	SVZ 200/18
300 L	600	40	1320	65	SVZ 300/24
400L	600	40	1650	65	SVZ 400/24

Tolerance  $\pm$  as per given general data in vessel chapter.

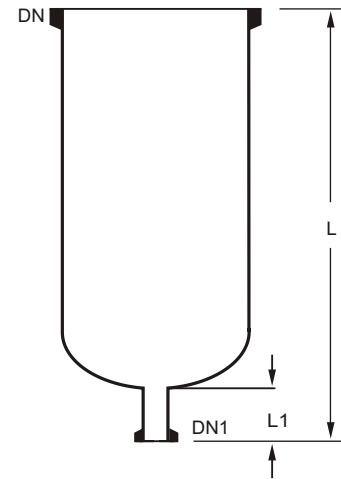

## CYLINDRICAL VESSEL COVERS

NOMINAL CAP. (LTR.)	DN	DN1	DN2	L	CAT. REF.
5 L	150	50	25 x 3	200	SVZA 5/6
10 L	150	50	25 x 3	200	SVZA 10/6
20 L	225	50	25 x 3	240	SVZA 20/12
30 L	300	50	25 x 3	225	SVZA 30/12
50 L	300	50	40 x 3	250	SVZA 50/12
	300	80	40 x 2	250	
100 L	450	50	40 x 2	325	SVZA 100/18
	450	80	40 x 2	325	
	450	100	40 x 2	350	
150 L	450	100	40 x 2	350	SVZA 150/18
200 L	450	100	40 x 2	350	SVZA 200/18
300 L	600	50	40 x 2	375	SVZA 300/24
	600	80	40 x 2	375	
	600	100	40 x 2	400	
400 L	600	100	40 x 2	400	SVZA 400/24

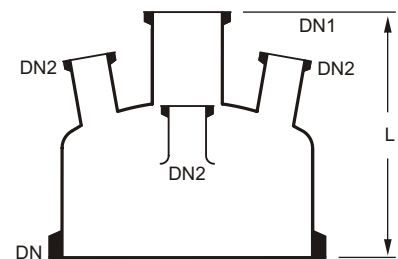

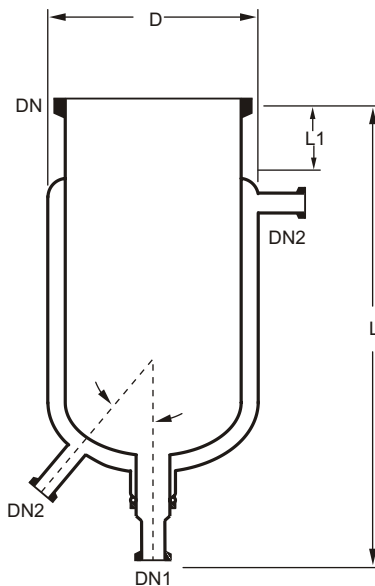
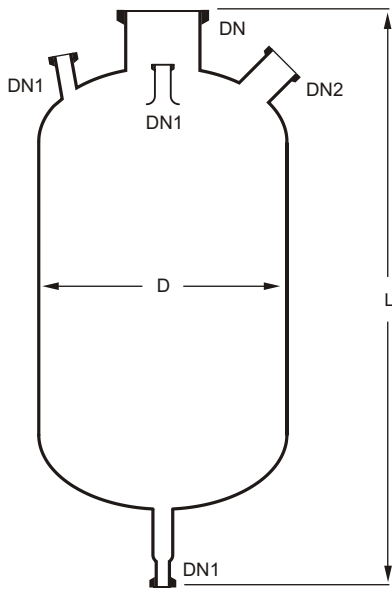
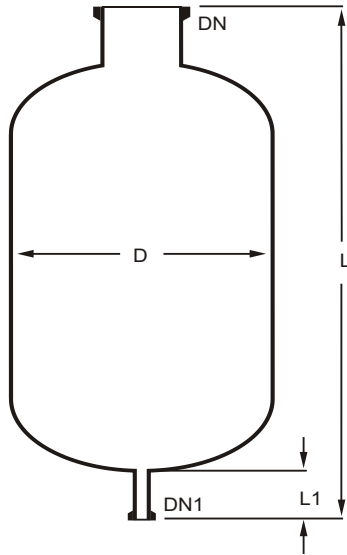

## CYLINDRICAL VESSELS RECEIVERS

NOMINAL CAP. (LTR.)	D	DN	DN1	L	L1	CAT REF.
20 L	300	100	25	650	60	SVZR20/12
30 L	300	150	40	800	65	SVZR30/12
50 L	300	150	40	1000	65	SVZR50/12
100 L	450	225	40	1100	65	SVZR100/18
150 L	450	225	40	1400	65	SVZR150/18
200 L	450	225	40	1625	65	SVZR200/18
300 L	600	225	40	1500	75	SVZR 300/24

Tolerance  $\pm$  as per given general data in vessel chapter.

## CYLINDRICAL FLASK

NOMINAL CAP. (LTR.)	D	DN	DN1	DN2 45 DEG.	L	CAT REF.
5 L	200	50	25	40	475	SVCY 5
10 L	220	50	25	40	600	SVCY 10
20 L	300	80	25	50	650	SVCY 20
30 L	300	80	25	50	790	SVCY 30
50 L	420	100	40	100	795	SVCY 50
100 L	470	150	40	100	1020	SVCY 100
150 L	470	150	40	100	1315	SVCY 150
200 L	600	225	40	100	1190	SVCY 200
300 L	600	225	40	100	1590	SVCY 300
400 L	650	300	40	100	1715	SVCY 400

Tolerance  $\pm$  as per given general data in vessel chapter.

## JACKETED VESSELS

Cylindrical vessel are available with a glass jacket for heating and cooling duties. The material of construction of the jacket, Borosilicate glass, has been taken in to design of the jacket seals. The jacket is fused directly to vessel or silicon rubber or viton 'O' Ring is used.

- Glass jacket can be used for a maximum operating pressure of 0.5 barg.
- Maximum operating temperature 130°C in jacket.
- Temperature difference between jacket & vessel should not exceed 120°C.

NOMINAL CAP. LTR.	DN	DN1	DN2	D	L	L1	REF. CAT.
5 L	100	25	25	165	825	150	SVZD 5/4
	150	25	25	220	600	150	SVZD 5/6
10 L	150	25	25	220	850	150	SVZD 10/6
	225	40	25	300	600	175	SVZD 10/9
20 L	225	40	25	300	900	175	SVZD 20/9
	300	40	25	390	650	200	SVZD 20/12
30 L	300	40	25	390	775	200	SVZD 30/12
50 L	300	40	25	390	1050	200	SVZD 50/12
60 L	300	40	25	390	1200	200	SVZD 60/12
100 L	400	40	25	460	1100	210	SVZD 100/16
	450	40	25	515	1000	210	SVZD 100/18

Tolerance  $\pm$  as per given general data in vessel chapter.

## VESSEL HOLDERS

Vessel holder are made of cast aluminum with a plaster lining shaped to fit the vessel. It is supported with three bolts.

VESSEL CAPACITY	CAT. REF.
10 L	SVSS 10
20 L	SVSS 20
30 L	SVSS 30
50 L	SVSS 50
100 L	SVSS 100
200 L	SVSS 200
300 L	SVSS 300

## VESSEL HOLDER RING

These metal rings are wrapped with asbestos rope and are to be supported with four bolts.

VESSEL CAPACITY	CAT. REF.
5 L	SVSR 5
10 L	SVSR 10
20 L	SVSR 20

## DIP PIPES

Dip pipes are used to feed material in vessels.

VESSEL CAP. (LTR.)	DN	DN1	D	L	L1	CAT. REF.
5 L	25	25	12	150	100	SDP 5
10 L	25	25	12	200	100	SDP 10
20 L	25	25	12	300	100	SDP 20
50 L	40	25	19	380	100	SDP 50
100 L	40	25	19	480	100	SDP 100
200 L	40	25	19	580	100	SDP 200
300 L	40	25	19	680	100	SDP 300

## SHORT DIP PIPES

Short dip pipe are used as re-entry tubes for vessels , Heat exchangers etc.

DN	DN1	D	L	L1	CAT. REF.
25	25	12	100	100	SDP 1/1
40	25	19	100	100	SDP 1.5/1
40	40	19	100	100	SDP 1.5/1.5
50	25	25	100	100	SDP 2/1
50	40	25	100	100	SDP 2/1.5
80	40	38	100	125	SDP 3/1.5
100	25	25	100	150	SDP 4/1
100	50	50	100	150	SDP 4/2
150	40	40	100	200	SDP 6/1.5
150	50	50	100	200	SDP 6/2

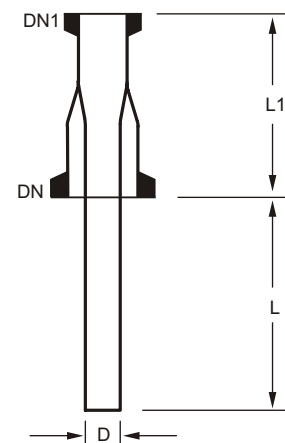
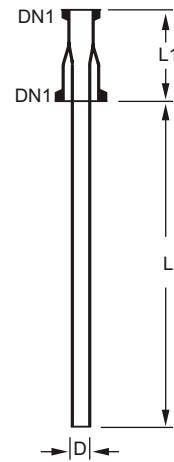
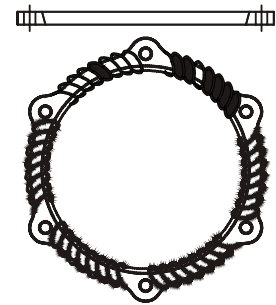
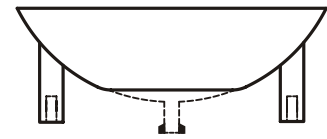



## THERMOMETER POCKETS

Thermometer pockets are used to put thermometer, where temperature need to be measured.

VESSEL CAP. (LTR.)	DN	D	L	L1	CAT REF.
5 L	25	12	150	50	STP 5
10 L	25	12	200	50	STP 10
20 L	25	12	300	50	STP 20
50 L	40	19	380	50	STP 50
100 L	40	19	480	50	STP 100
200 L	40	19	580	50	STP 200
300 L	40	19	680	50	STP 300

## STIRRERS

A variety of stirrers and stirrer drives are available to use glass vessel as agitated reaction equipment. Stirrers assemblies are used with spherical or cylindrical vessels generally comprise two main components : a drive unit ( including shaft seal ) and a stirrer shaft. In addition a reducer or vessels cover is normally required to connect the top neck of the vessel to the drive unit . Variable speed drive units can be supplied on request .

## CHUCK & SEAL

This unit is suitable to use under corrosive conditions. Only GLASS & PTFE are exposed to process fluids. Bellow seal can be used under vacuum down to 10 mm Hg absolute. Mechanical seal can be use under vacuum 1mm Hg absolute or under pressure permitted in to glass vessels.

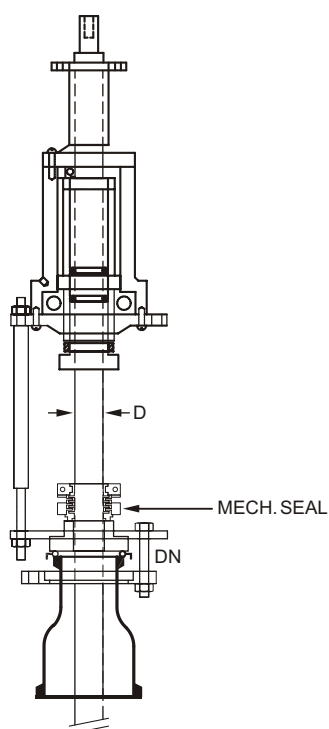

VESSEL CAP. (LTR.)	DN	D	CAT. REF.	
			BELLOW SEAL	MECH. SEAL
10 L	50	24.5	SCSA1	SCSM 1
20 L	50	24.5	SCSA1	SCSM 1
50 L	50	24.5	SCSA1	SCSM 1
100 L	80	45.5	SCSA1.5	SCSM 1.5
200 L	80	45.5	SCSA1.5	SCSM 1.5
300 L	80	45.5	SCSA1.5	SCSM 1.5

## GLASS STIRRER WITH TEFLON BLADE.

These stirrers are used for low viscosity fluid.

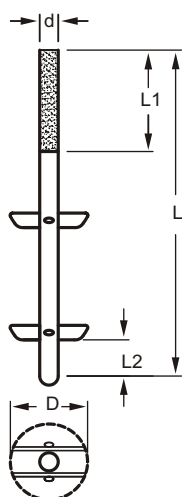

VESSEL CAP. (LTR.)	d	D	L	L1	CAT. REF.	
					L2	MECH. SEAL
5L	24.5	40	625	350	25	SSTB 5
10 L	24.5	40	700	350	25	SSTB10
20 L	24.5	70	800	350	25	SSTB20
50 L	24.5	90	1000	350	25	SSTB50
100 L	45.5	140	1200	375	30	SSTB100
200 L	45.5	170	1400	400	30	SSTB200
300 L	45.5	170	1500	400	30	SSTB300



## VORTEX STIRRER

These stirrers are used for low viscosity fluid containing small solid particles.

VESSEL CAP. (LTR.)	d	D	L	L1	L2	CAT. REF. MECH. SEAL
5L	24.5	40	625	350	50	SSTV 5
10 L	24.5	40	700	350	50	SSTV 10
20 L	24.5	50	800	350	50	SSTV 20
50 L	24.5	65	1000	350	65	SSTV 50
100 L	45.5	65	1200	375	65	SSTV 100
200 L	45.5	105	1400	400	65	SSTV 200
300 L	45.5	105	1500	400	65	SSTV 300

## PROPELLER STIRRER

These stirrers are used for high viscosity fluid or liquid with big solid particles.

VESSEL CAP. (LTR.)	d	D	L	L1	L2	CAT. REF. MECH. SEAL
5L	24.5	40	625	350	50	SSTP5
10 L	24.5	40	700	350	50	SSTP10
20 L	24.5	50	800	350	50	SSTP20
50 L	24.5	65	1000	350	65	SSTP50
100 L	45.5	65	1200	375	65	SSTP100
200 L	45.5	105	1400	400	65	SSTP200
300 L	45.5	105	1500	400	65	SSTP200

## DRIVE ASSEMBLY FOR GLASS STIRRERS WITH BELLOW SEAL

A stirrer is assembled in chuck with bellow seal and appropriate reducer. This assembly is convenient to install on a vessel. These assembly mainly consist of:

- Glass Stirrer (SSTB / SSTV / SSTP)
- Chuck and seal assembly (SCSA)
- Reducer (SPR)

These stirrers are used for high viscosity fluid or liquid with big solid particles.

VESSEL CAPACITY	STIRRER USED	CHUCK & SEAL USED	REDUCER USED	CAT. REF.
10 L	SSTB 10	SCSA 1	-	SSTBA 10
20 L	SSTB 20	SCSA 1	SPR 3/2	SSTBA 20
50 L	SSTB 50	SCSA 1	SPR 4/2	SSTBA 50
100 L	SSTB 100	SCSA 1.5	SPR 6/3	SSTBA 100
200 L	SSTB 200	SCSA 1.5	SPR 9/3	SSTBA 200
300 L	SSTB 300	SCSA 1.5	SPR 12/3	SSTBA 300
10 L	SSTV 10	SCSA 1	-	SSTVA 10
20 L	SSTV 20	SCSA 1	SPR 3/2	SSTVA 20
50 L	SSTV 50	SCSA 1	SPR 4/2	SSTVA 50
100 L	SSTV 100	SCSA 1.5	SPR 6/3	SSTVA 100
200 L	SSTV 200	SCSA 1.5	SPR 9/3	SSTVA 200
300 L	SSTV 300	SCSA 1.5	SPR 12/3	SSTVA 300
10 L	SSTP 10	SCSA 1	-	SSTPA 10
20 L	SSTP 20	SCSA 1	SPR 3/2	SSTPA 20
50 L	SSTP 50	SCSA 1	SPR 4/2	SSTPA 50
100 L	SSTP 100	SCSA 1.5	SPR 6/3	SSTPA 100
200 L	SSTP 200	SCSA 1.5	SPR 9/3	SSTPA 200
300 L	SSTP 300	SCSA 1.5	SPR 12/3	SSTPA 300

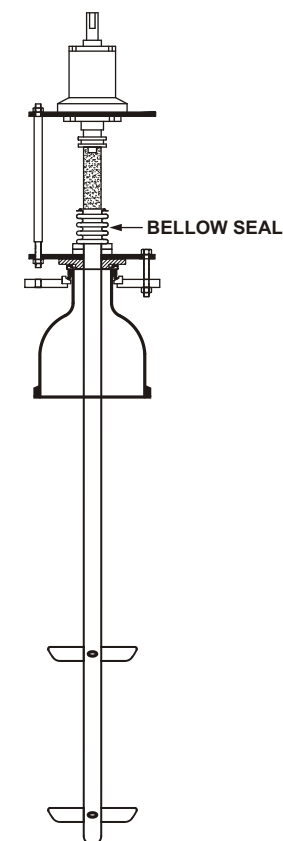
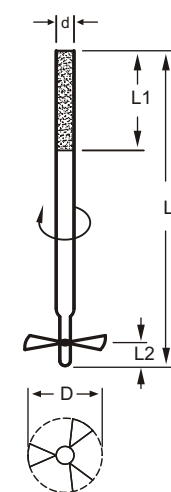
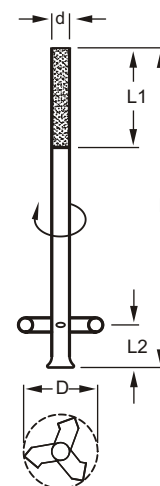

## DRIVE ASSEMBLY FOR GLASS STIRRERS WITH MECHANICAL SEAL

A stirrer is assembled in chuck with mechanical seal and appropriate reducer. This assembly is convenient to install on a vessel. These assembly mainly consist of :

- A . Glass Stirrer ( SSTB/ SSTV/ SSTP)
- B. Chuck and mechanical seal ( SCSM)
- C. Reducer ( SPR)

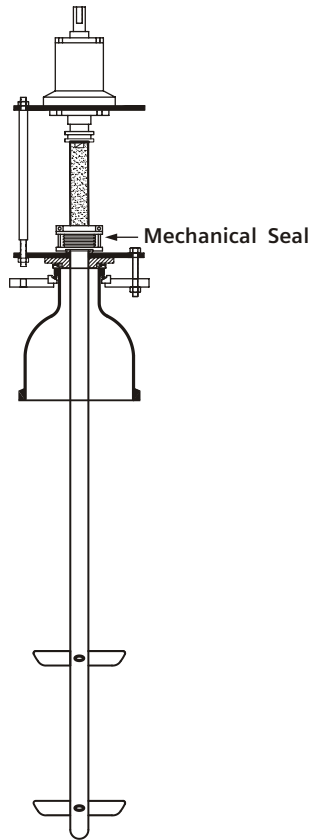

VESSEL CAPACITY	STIRRER USED	CHUCK & SEAL USED	REDUCER USED	CAT. REF.
10 L	SSTB 10	SCSA 1	-	SSTBM10
20 L	SSTB 20	SCSA 1	SPR 3/2	SSTBM20
50 L	SSTB 50	SCSA 1	SPR 4/2	SSTBM50
100 L	SSTB 100	SCSA 1.5	SPR 6/3	SSTBM 100
200 L	SSTB 200	SCSA 1.5	SPR 9/3	SSTBM 200
300 L	SSTB 300	SCSA 1.5	SPR 12/3	SSTBM 300
10 L	SSTV10	SCSA 1	-	SSTVM 10
20 L	SSTV20	SCSA 1	SPR 3/2	SSTVM 20
50 L	SSTV50	SCSA 1	SPR 4/2	SSTVM 50
100 L	SSTV100	SCSA 1.5	SPR 6/3	SSTVM 100
200 L	SSTV200	SCSA 1.5	SPR 9/3	SSTVM 200
300 L	SSTV300	SCSA 1.5	SPR 12/3	SSTVM 300
10 L	SSTP 10	SCSA 1	-	SSTPM 10
20 L	SSTP 20	SCSA 1	SPR 3/2	SSTPM 20
50 L	SSTP 50	SCSA 1	SPR 4/2	SSTPM 50
100 L	SSTP 100	SCSA 1.5	SPR 6/3	SSTPM 100
200 L	SSTP 200	SCSA 1.5	SPR 9/3	SSTPM 200
300 L	SSTP 300	SCSA 1.5	SPR 12/3	SSTPM 300

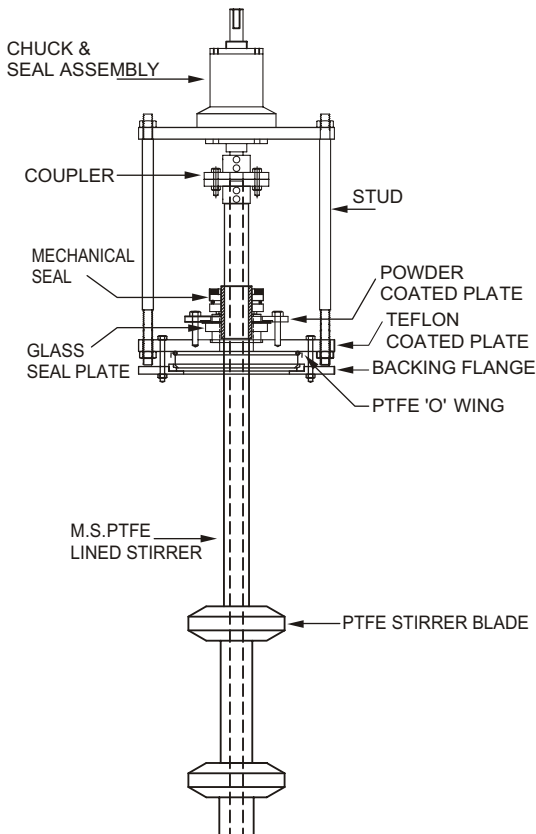

## M.S. PTFE LINED STIRRER

A Stirrer assembled with chuck & mechanical seal. This assembly is convenient to install on a vessel. These assembly mainly consists of :

- a. M.S. PTFE Lined Stirrer
- b. Chuck and Mechanical Seal
- c. Teflon Coated Plate
- d. PTFE Impeller

## BATHS

### COOLING BATHS

Cooling baths are used for cooling the glass vessel with ice crystals. Cooling baths are provided with a vessel holding ring, bottom outlet sealing arrangement and a lid.

VESSEL CAP. (LTR.)	D	L	CAT. REF.
5 L	325	225	SBHC 5
10 L	350	250	SBHC 10
20 L	480	330	SBHC 20
50 L	615	415	SBHC 50
100 L	720	510	SBHC 100
200 L	900	620	SBHC 200

### HEATING BATHS - WITH COIL & HEATER

M.S. Heating baths are used with electrical or steam heating for glass vessel. Depending upon the temperature requirements, different types of thermic fluids or water can be used as heating media. Heating baths are provided with a pair of non flame proof heaters, M.S. Coil for passing the steam or cooling water, cushioned vessel holder, a bottom outlet sealing arrangement, a lid and threaded socket type or flange type inlet and outlets.

VESSEL CAP. (LTR.)	D	L	LOADING KW	CAT. REF.
5 L	325	225	2 (2x1000)	SBH 5
10 L	350	250	2 (2x1000)	SBH 10
20 L	480	330	3 (3x1000)	SBH 20
50 L	615	415	4.5 (3x1500)	SBH 50
100 L	720	510	6 (3x2000)	SBH 100
200 L	900	620 </td <td>9 (3x3000)</td> <td>SBH 200</td>	9 (3x3000)	SBH 200

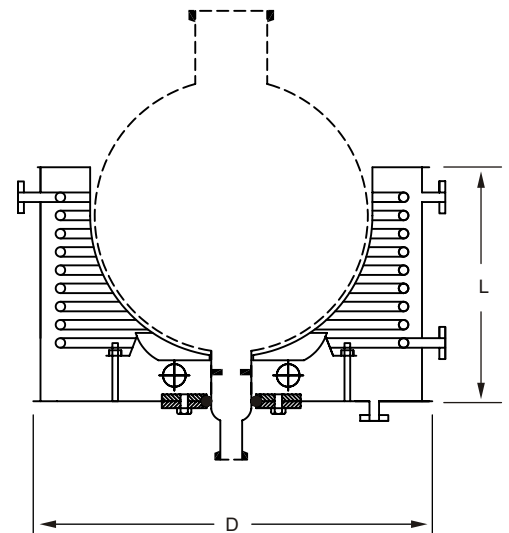
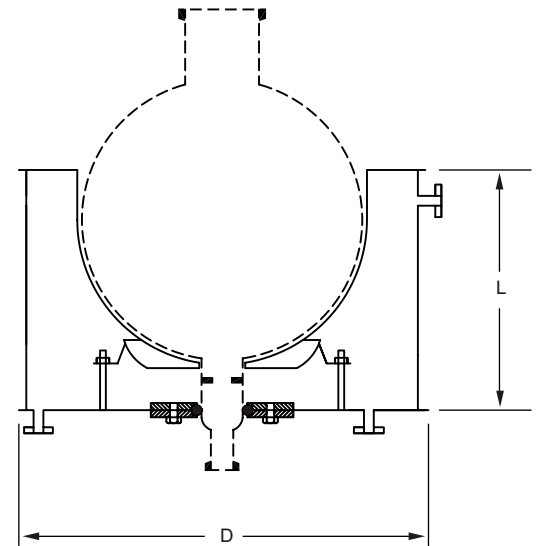

## HEATING BATHS - JACKETED WITH COIL

MS Jacketed heating bath is provided with a coil inside to circulate either steam or heat transfer fluid depending upon the application. Provision for insertion of Electrical heater is also kept.

(Non-flame proof) Heater can also be provided along with the bath on request. Although the standard heating baths are specifically designed for spherical vessels, similar baths for cylindrical vessels can also be supplied to special order. All these heating baths can be fitted with suitable temperature control equipment if required.

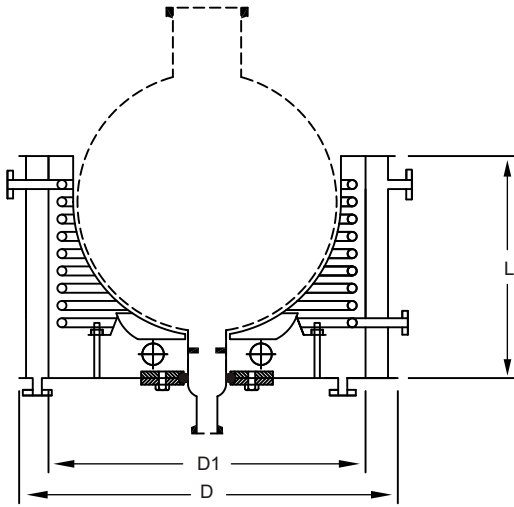

VESSEL				
CAP. (LTR.)	D1	D	L	CAT. REF.
5 L	325	395	260	SBHD5
10 L	350	420	285	SBHD10
20 L	480	550	365	SBHD 20
50 L	635	685	465	SBHD 50
100 L	730	830	560	SBHD 100
200 L	900	1050	680	SBHD 200

### Notes:

1. Powder coating / S.S. Heating bath can be supplied on request. This should be specified during inquiry stage.
2. S.S. / Copper coil can be supplied on request. This should be specified during inquiry stage.

## HEATING MANTLES

As an alternative to heating baths electric heating mantles can also be supplied for spherical vessels. Their heating power varies according to the nominal capacity of the vessel involved.

These heating mantles are subdivided into several heating zones each of which is equipped with a temperature probe so that the surface temperature of the vessel can be monitored. These work in conjunction with the control unit included in the supply to prevent local hot spots occurring. The control unit also includes energy regulators, which can be used to control the heat input separately for each heating zone depending on the liquid level.

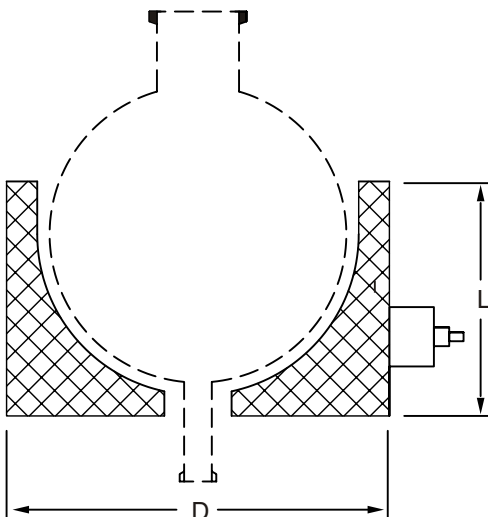

VESSELS CAPACITY	D	L	LOADING KW	CIRCUITS	SUPPLY	CAT. REF.
5	-	-	0.6 (1x600)	1	230V	SJMD 5
10	-	-	1.0 (2X500)	3	230V	SJMD 10
20	470	245	1.5 (3X500)	3	230V	SJMD 20
50	610	305	3.6 (6X900)	3	440V	SJMD 50
100	715	360	5.4 (6X900)	3	440V	SJMD 100
200	890	450	8.1 (9X900)	3	440V	SJMD 200

**Note :** In all cases, electrical supply should be specified when ordering. All Heating mantle are non-flame proof type. Flame proof heating mantle can be supplied on request.

## MOTOR WITH REDUCTION GEAR BOX

Flameproof motor with reduction gearbox is supplied as standard. A motor is coupled with gearbox. The other end of the gearbox is coupled with flexible shaft.

1:7 Reduction gearbox is used with motor. 1:10 reduction gearbox can also be supplied on request. This should be specified at the time of enquiry stage.

**SPECIFICATION** : 1400 RPM, 415V, 50Hz, 3 Phase supply, insulation class F, degree of protection : IP 55.

H.P.	SPEED	CAT. REF.
0.5	190	SFSD 0.5/190
0.5	130	SFSD 0.5/130
0.25	190	SFSD 0.25/190
0.25	130	SFSD 0.25/130

## SPEED VARIATOR

Different variable speed stirrer drives are available for adjusting stirrer speeds to different operating conditions.

### MECHANICAL VARIATOR

Mechanical variator have been designed for either horizontal or vertical mounting, one end of the mechanical variator is coupled with motor shaft and other end is fitted with reduction gear box. Control for speed regulation is attached to one end of the control shaft. Hand wheel control is standard control provided on the unit, where selected speed can be read on the indication drum. Variable output speed between lowest 1/7 of the input speed and highest 1.7 times of the input speed can be adjusted. The variator can run in either direction at the rated HP.

### FREQUENCY VARIATOR

Non-flameproof digital microprocessor AC variable speed drives (inverters) is also available to adjust the speed of motor. This VARIATOR has got LED display for frequency, speed, setting value, voltage etc. Frequency is set by keypad or external analog signal.

Power supply: 3 Phase, 440V, 50Hz.

Flameproof version can also be supplied on request. This should be specified at the time of enquiry stage.

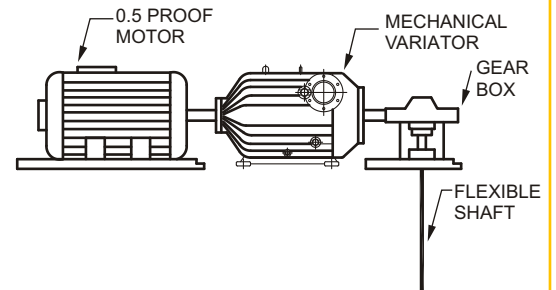
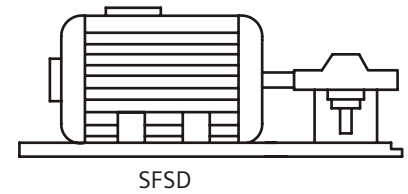

## MEASUREMENT AND CONTROL

### DIGITAL TEMPERATURE INDICATOR

This instrument is mainly used to monitor temperature of liquid in a typical glass distillation unit.

This instrument mainly consists of : temperature Indicator and Resistance Temperature Detectors (RTD). This instrument works on 230V, 50 Hz power supply. This displays the temperature in degree Centigrade (°C).

VESSEL CAPACITY (Ltr.)	RTD LENGTH	CAT. REF.
20	400	SDTI 20
50	500	SDTI 50
100	600	SDTI 100
200	700	SDTI 200

### TWO POINT DIGITAL TEMPERATURE INDICATOR

This instrument is mainly used to monitor temperature of liquid in a glass vessel and temperature of vapours of reflux divider in a typical glass distillation unit. This instrument mainly consists of Temperature Indicator and Two Resistance Temperature Detectors (RTD). This instrument works on 230V, 50Hz power supply. This display temperature in degree Centigrade (°C) a switch is provided to see the two temperature alternatively.

VESSELS CAPACITY(Ltr.)	RTD LENGTH FOR VESSEL	RTD LENGTH FOR REFLUX DIVIDER	CAT. REF.
20	400	200	STDTI 20
50	500	225	STDTI 50
100	600	250	STDTI 100
200	700	300	STDTI 200

### CONTINUOUS TEMPERATURE CONTROLLER

This instrument displays and controls temperature continuously by switching the power supply ON and OFF in an electrical heating equipment as per the initial settings of heating temperature, band width and reset temperature. This instrument mainly consists of a Temperature controller, a series magnetic controller and a Resistance Temperature Detectors(RTD).

RTD is put into the thermometer pocket of the glass vessel and desired settings are done. As temperature, in the vessels reaches to the set heating temperature, the temperature controller cuts the power in heating equipment OFF. Power starts ON again as the temperature goes down as per the settings of band width and reset temperature.

This instrument works on power supply of 230V 50Hz and can be used with heating mantles and heating baths of all sizes. It displays temperature in Degree Centigrade (°C).

VESSEL CAPACITY(Ltr.)	RTD LENGTH	CAT. REF.
20	400	SCTC 20
50	500	SCTC 50
100	600	SCTC 100
200	700	

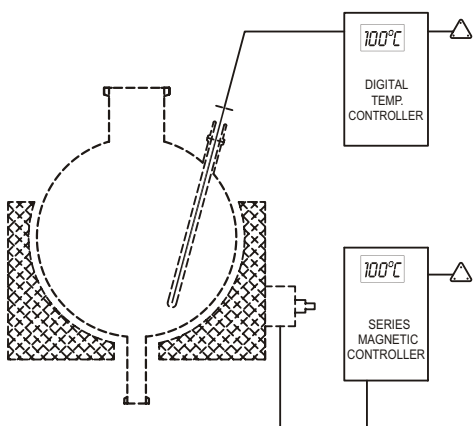
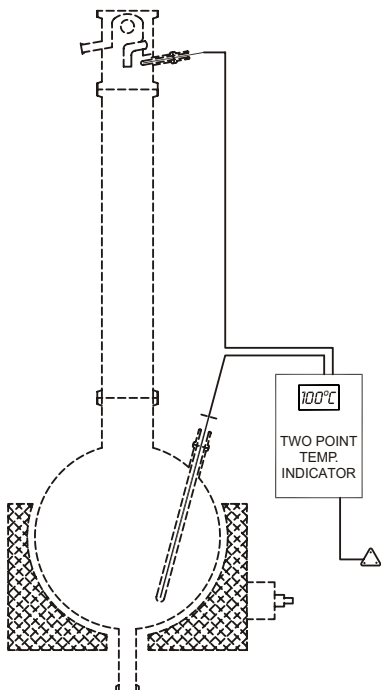
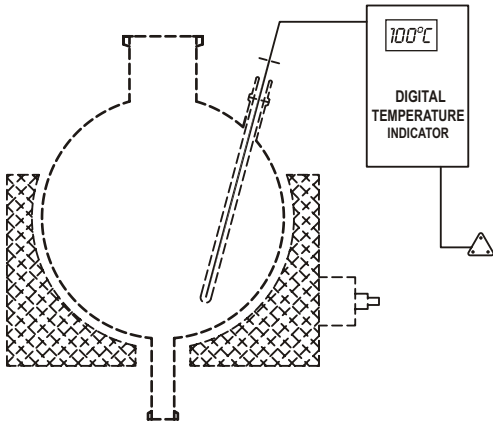

## SEPARATORS

Separators are used to separate two immiscible liquids with different densities. When these liquids allowed settling forms two separate layers, heavier at bottom and lighter at up. Mixture of liquid is continuously feeded in separator at low velocity. This allow sufficient residence time for the formation of separating layers. Light phase liquid is continuously removed from light phase outlet at the top. The Heavy phase liquid enters through dip pipe at lower end and overflows in the discharge pipe and is removed from the bottom outlet.

Separator can be provided with Adjustable overflow valve, (Type B) to adjust position of interface for different operating situations. Separator can also be constructed with horizontal cylindrical vessel and to provide lager-separating surface. (Cat Ref. HSPS OR HSPA).

NOM. CAP	INLET DN	HEAVY PHASE OUTLET			LIGHT PHASE OUTLET VENT			L	L1	L2	L3	TYPE	CAT REF
		DN2	DN3	DN4	DN5	DN6	DN6						
20 L	80	25	50	25	25	25	25	800	125	525	-	A	SSPS20
50 L	100	40	50	25	25	40	40	1025	150	725	-	A	SSPS50
100 L	150	40	50	25	25	40	40	1175	200	825	-	A	SSPS100
200 L	225	40	50	25	25	40	40	1475	250	1075	-	A	SSPS200
20 L	80	25	50	25	25	25	25	1000	125	525	200	B	SSPA20
50 L	100	40	50	25	25	40	40	1225	150	725	200	B	SSPA50
100 L	150	40	50	25	25	40	40	1375	200	825	200	B	SSPA100
200 L	225	40	50	25	25	40	40	1675	250	1075	200	B	SSPA200

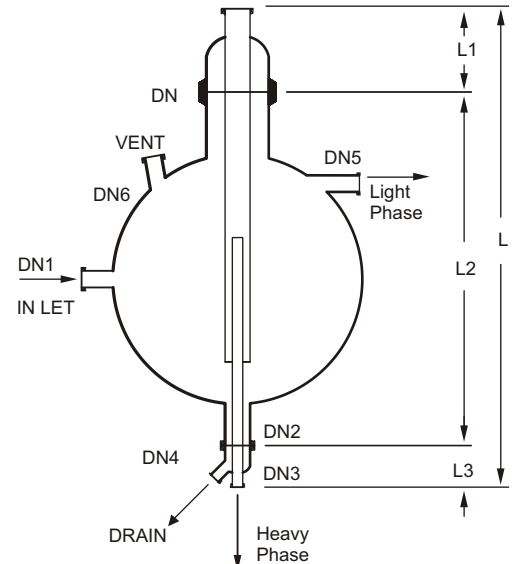

**TYPE-A**

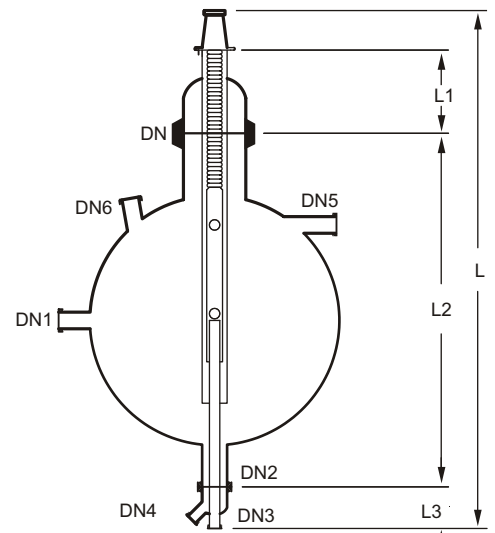

**TYPE-B**

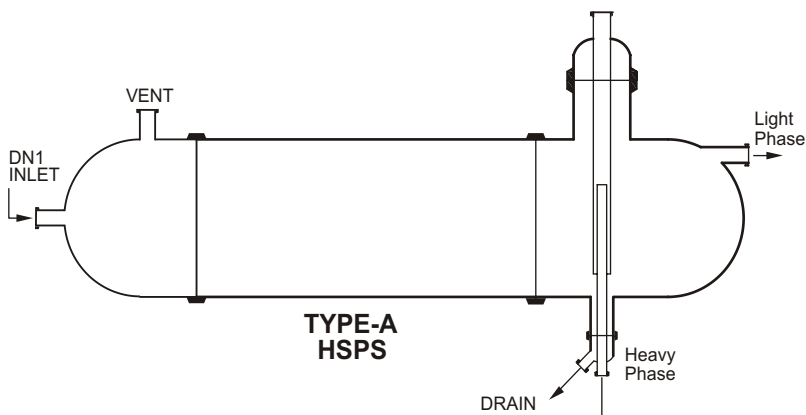

**TYPE-A  
HSPS**

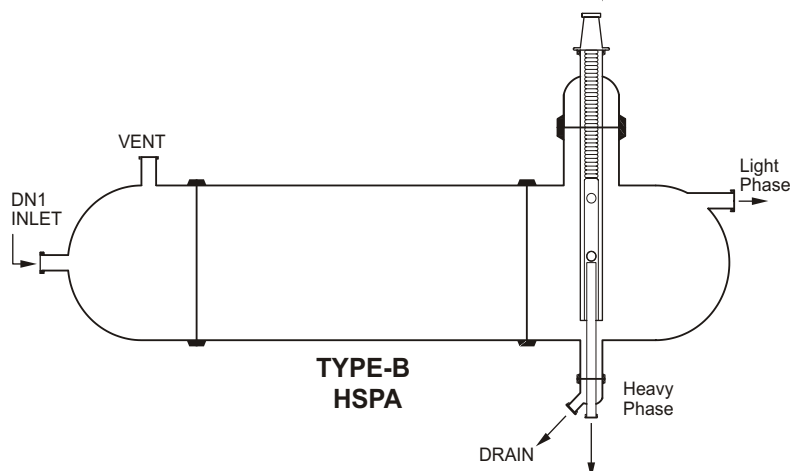

**TYPE-B  
HSPA**

## CYCLONES

Cyclones are designed for separation not only for droplets from gases and vapours, but also for particulate solids from gases.

The overall degree of separation can be as high as 99% but this figure is governed to a large extent by the following factors.

- Liquid loading of the gas or vapour or solids loading of the gas.
- Droplet or particle size range.
- Droplet or particle size distribution.

The following are examples of limiting droplet diameters for the standard air/water system (at ambient temperature) with a velocity in the dip pipe of 15m/sec.

DN	DN1	DN2	DN3	DN4	L	L1	L2	L3	L4	L5	CAT. REF.
100	40	25	80	40	715	560	130	125	35	180	SCY4
150	50	25	100	50	850	665	165	150	55	235	SCY6
225	80	25	150	80	1120	870	225	200	75	320	SCY9
300	100	25	150	100	1430	1115	285	275	100	405	SCY12

## CYCLONES WITH INTERNAL COOLING COIL

DN	DN1	DN2	DN3	L	L1	L2	L3	L4	L5	CAT. REF.
100	40	25	40	715	560	130	125	35	330	SCY 4
150	50	25	50	850	665	165	150	55	375	SCY 6
225	80	25	80	1120	870	180	200	75	500	SCY 9
300	100	25	100	1430	1155	215	275	100	675	SCY 12

