



COLUMN COMPONENTS

Column components are widely used in chemicals, pharmaceutical and allied industries together with other applications e.g. food and drink production, dye works and electroplating. This is because of the special properties of borosilicate glass 3.3 and PTFE together with special materials that are used in some instances for internals, plus the fact that borosilicate glass 3.3 is an approved and proven material of construction for pressure vessels.

1. With almost universal resistance to corrosion, a long service life is guaranteed and maintenance is kept to a minimum.
2. Their transparency permits constant visual monitoring of the process at all times.
3. Being inert, the risk of contamination is negligible.
4. Smooth surface allow easy cleaning and sterilization and prevent the build-up of solids on the inner walls.

COLUMN SECTIONS

All column sections are supplied complete with support. The packing must be ordered separately.

On special request. A column sections can be supplied without the packing support. Column sections and pipe sections may be used for the construction of columns of all nominal bores provided that the weight of the packing and retained liquid does not exceed the load-bearing capacity of the support. Column section can also be provided with a thermometer branch below the packing support.

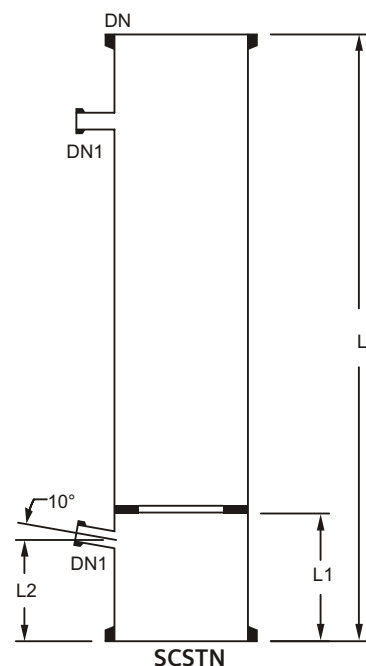
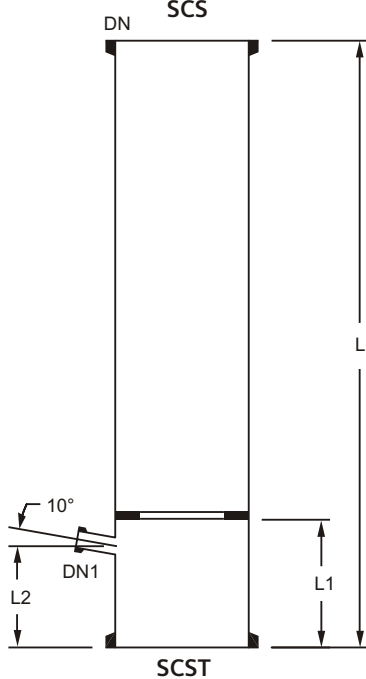
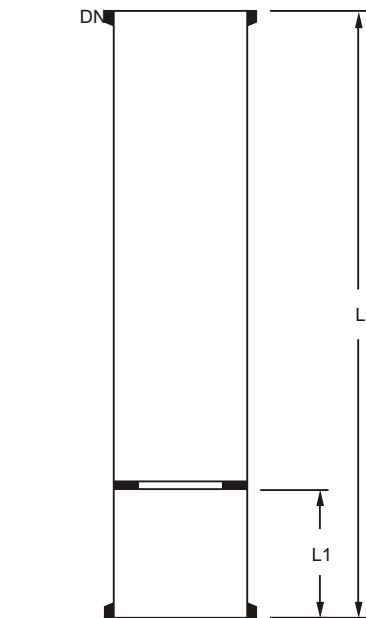

DN	DN1	L	L1	L2	CAT. REF. SCS / SCST / SCSTN
80	25	1000	125	100	3/1000
100	25	1000	125	100	4/1000
150	25	1000	125	100	6/1000
225	25	1000	125	100	9/1000
225	25	1500	150	125	9/1500
300	25	1000	150	125	12/1000
300	25	1500	150	125	12/1500
400	25	1000	200	150	16/1000
400	25	1500	200	150	16/1500
450	25	1000	200	150	18/1000
450	25	1500	200	150	18/1500
600	25	1500	200	150	24/1500

PACKING SUPPORTS

Two types of packing supports Type A or Type B. Type A are made of fused glass rods and Type B (heavy duty) are made of glass plates vertically arranged and tied with PTFE tie rods.

Standard packing supports for columns DN 80 to DN 300 are manufactured from borosilicate glass. From DN 400 and above, a combination of glass and PTFE is used for their construction, thus maintaining maximum resistance to corrosion.

DN	L	MAXIMUM LOAD (Kg)	MAXIMUM PACKING SIZE (mm)	TYPE	CAT. REF.
80	20	10	12	A	SLB 3
100	20	15	15	A	SLB 4
150	30	30	25	A	SLB 6
225	30	50	25	A	SLB 9
300	30	75	25	A	SLB 12
400	70	150	25	B	SHD 16
450	70	200	25	B	SHD 18
600	95	300	40	B	SHD 24

SUPPORT PLATE ASSEMBLY

If free cross-section obtained with the combination of column section and packing support are not large enough, then an alternative is to be used with pipe sections in combination with fixed support plate.

Each item comprises glass support plate, screwed rod with nuts, flat washers, compression springs and special backing flange for assembly.

DN	L	MAXIMUM LOAD (Kg)	CAT. REF.
80	25	10	SLBE 3
100	25	15	SLBE 4
150	50	30	SLBE 6
225	50	50	SLBE 9
300	50	75	SLBE 12

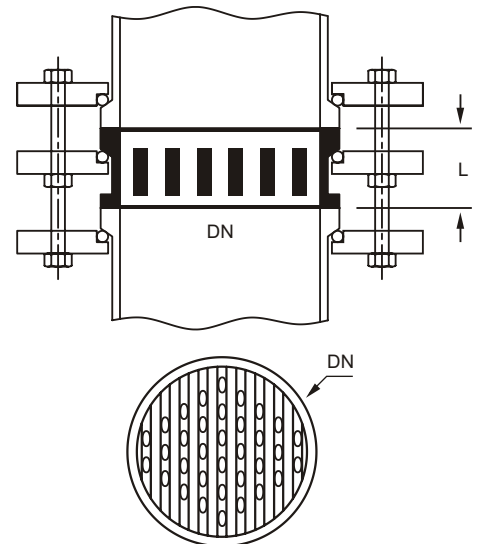
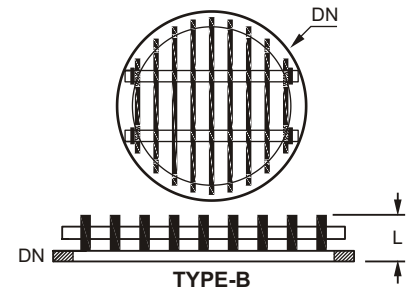
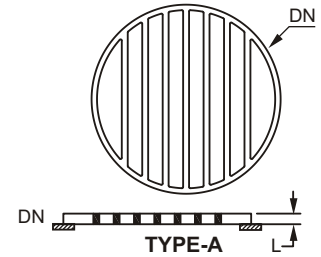

COLUMN PACKING RASCHING – RINGS

Rasching rings up to 25mm are made of neutral glass. 40mm and 50mm Rasching Rings are available in borosilicate glass.

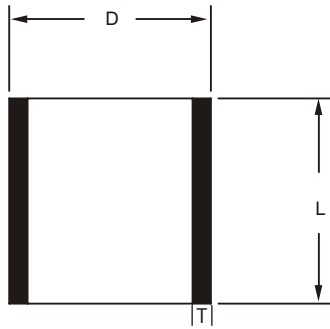

D X L	WALL THICKNESS (T)	BULK DENSITY (Kg/Ltr.)	SPECIFIC SURFACE (M ² /M ³)	CAT. REF.
8 X 8	1.0	0.60	500	SFC 8
12 X 12	1.0	0.50	400	SFC 12
15 X 15	1.6	0.75	300	SFC 15
20 X 20	1.1	0.45	280	SFC 20
25 X 25	2.0	0.27	200	SFC 25
30 X 30	2.0	0.40	176	SFC 30
40 X 40	1.75	0.27	160	SFC 40
50 X 50	2.0	0.25	120	SFC 50

PACKINGS REQUIRED FOR VARIOUS COLUMN SECTIONS (Kgs.)

PACKING SIZE (mm)

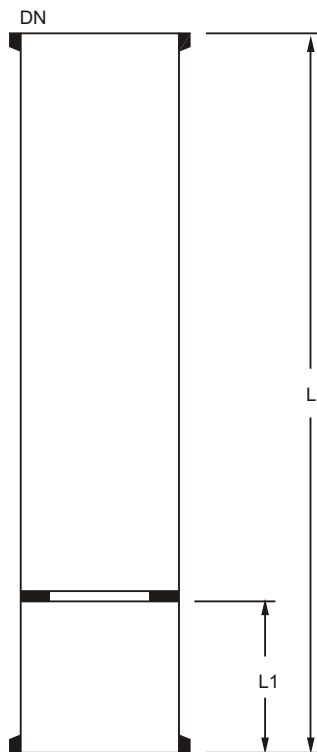

COLUMN SECTION SIZE	Vol LITER	SFC 8	SFC 12	SFC 15	SFC 20	SFC 25	SFC 30	SFC 40	SFC 50
SCS 3/1000	4.4	2.6	2.2	3.3	2.0	1.2	1.8	1.2	1.1
SCS 4/1000	7.6	4.6	3.8	5.7	3.4	2.1	3.0	2.1	1.9
SCS 6/1000	15.5	9.3	7.8	11.6	7.0	4.2	6.2	4.2	3.9
SCS 9/1000	31.8	19.1	15.9	23.9	14.3	8.6	12.7	8.6	8.0
SCS 12/1000	61.9	37.1	31.0	46.4	27.9	16.7	24.8	16.7	15.5
SCS 16/1000	110	66.0	55.0	82.5	49.5	29.7	44.0	29.7	27.5
SCS 18/1000	145	87.0	72.5	108.8	65.3	39.2	58.0	39.2	36.3
SCS 24/1000	255	153.0	127.5	191.3	114.8	68.9	102.0	68.9	63.8

Notes of use of column packing

1. Due to their low bulk density, glass rasching rings are particularly suitable for packing glass columns.
2. Generally the ratio of column diameter to packing diameter should not be less than 8:1.
3. When using smaller packing size, a small layer of larger packing should be used on packing support, to prevent the smaller packing falling through.
4. In vacuum application and applications involving high vapour velocities, packing may be lifted and may damage to other parts. To prevent this, a packing retainer (PTFE perforated plates) should be used above the packed section.

PTFE RE-DISTRIBUTORS

PTFE re-distributors are installed in the same way as gaskets between two flat buttress end faces and therefore when using them, no gasket is required.

DN	D	L	CAT. REF.
40	28	10	STL 1.5
50	35	10	STL 2
80	55	10	STL 3
100	70	15	STL 4
150	105	15	STL 6
225	140	15	STL 9
300	200	15	STL 12

PACKING RETAINERS / PTFE PERFORATED PLATES

Packing retainers are installed above packed column section to prevent any carry-over of column packing. They are installed in the same way as gaskets between two flat buttress end faces and therefore no gasket is required. Packing retainers are manufactured from PTFE for maximum resistance to corrosion. They cannot be used as packing supports.

DN	L	FREE CROSS SECTION AREA (%)	CAT. REF.
80	7	80	SCPP 3
100	7	90	SCPP 4
150	7	90	SCPP 6
225	10	95	SCPP 9
300	10	85	SCPP 12

COLUMN FEED PIPE

Column feed pipes are designed for application in which there is need to introduce the process liquid at a single point. They are usually installed SPTU unequal tee piece (see Chapter 2 of this catalogue - Pipeline Components) and used as a distribution tube, which directs the fluid down onto center of column packing.

Column feed pipes are available for 80 DN to 600 DN column. Two types of column feed pipes are available as under :

- (1) Dip pipe type (Type-A) (2) Plate type (Type-B)

DN	DN1	DN2	D	L	L1	CAT. REF.
80	40	25	13	100	115	SFP 3
100	40	25	13	125	115	SFP 4
150	40	25	13	150	115	SFP 6
225	40	25	13	185	115	SFP 9
300	40	25	13	230	115	SFP 12
450	80	40	25	320	150	SFP 18
600	150	50	40	450	200	SFP 24

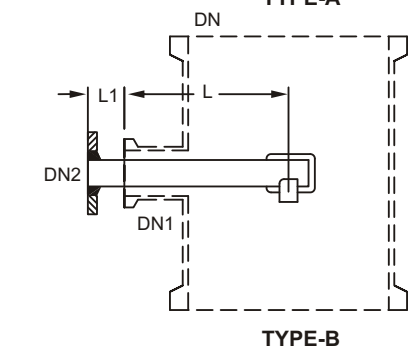
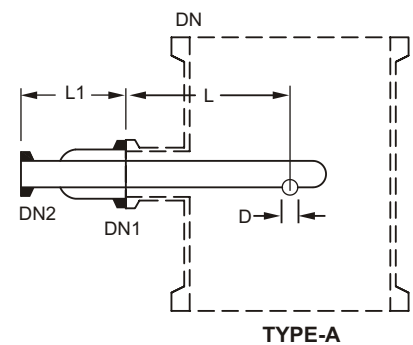
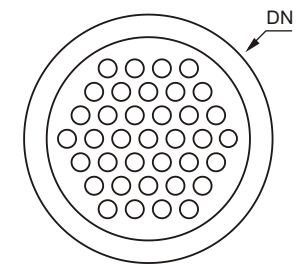
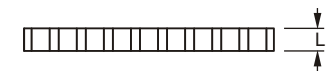
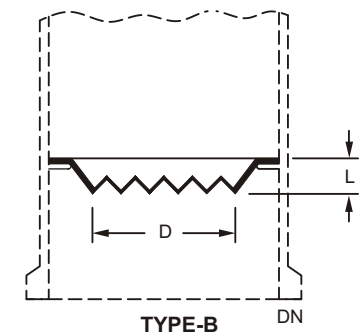
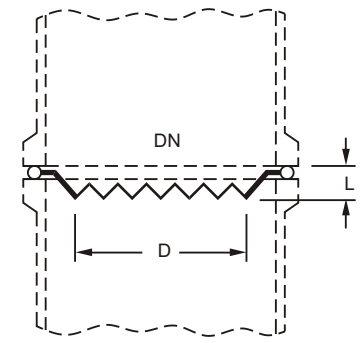

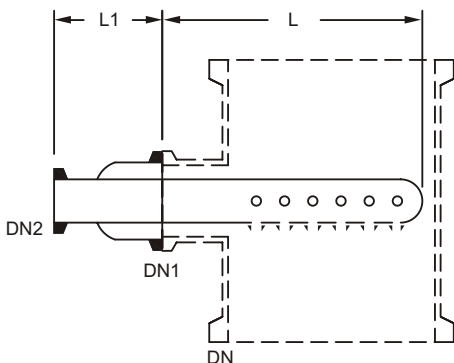
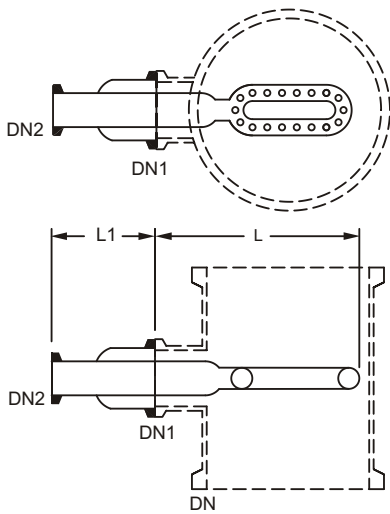
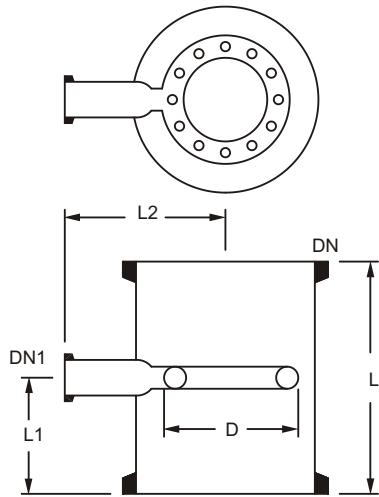

SPRAY FEED SECTIONS

Spray feed sections are provided with circular tube having holes at bottom

DN	DN1	L	L1	L2	DIA OF HOLE X NO. OF HOLES	CAT. REF.
80	25	200	100	100	2 x 20	SFR 3
100	25	250	125	110	2 x 20	SFR 4
150	25	250	125	150	2 x 27	SFR 6
225	25	250	125	170	2 x 27	SFR 9
300	25	300	150	220	2 x 30	SFR 12

SPRAY FEED PIPES

Like column feed pipes, spray feed pipes are usually installed via a SPTU unequal tee piece. Spray feed pipes sections are provided with oval tube having holes at bottom.

DN	DN1	L	L1	L2	DIA OF HOLE X NO. OF HOLES	CAT. REF.
150	80	25	225	125	2 x 27	SFD 6
225	100	25	325	150	2 x 27	FSD 9
300	150	25	400	200	3 x 30	FSD 12
450	150	50	500	200	3 x 40	SFD 18
600	150	50	600	200	3 x 60	SFD 24

COLUMN FEED SPARGER

In column feed sparger holes are provided at three sides of pipe.

DN	DN1	L	L1	L2	DIA OF HOLE X NO. OF HOLES	CAT. REF.
80	25	25	125	100	2 x 21 No.	SSPG 3
100	25	25	150	100	2 x 21 No.	SSPG 4
150	40	25	200	100	2 x 27 No.	SSPG 6
225	40	25	275	100	2 x 27 No.	SSPG 9
300	40	25	350	100	3 x 30 No.	SSPG 12
450	40	25	500	100	3 x 39 No.	SSPG 18
600	50	40	650	100	3 x 60 No.	SSPG 24

COLUMN ADAPTORS - FLAT TOP

These are generally used as end bonnets of shell & tubes heat exchangers and columns.

DN	DN1	L	L1	L2	CAT. REF.
150	40	155	110	165	SFH 6/1.5
225	40	165	120	200	SFH 9/1.5
300	40	190	140	240	SFH 12/1.5
450	40	285	175	300	SFH 18/1.5
450	150	420	310	380	SFH 18/6

COLUMN ADAPTORS

DN	DN1	DN2	L	L1	L2	CAT. REF.
80	25	25	180	90	95	SCA 3/1/1
80	40	25	180	90	110	SCA 3/1.5/1
100	25	25	205	100	110	SCA 4/1/1
100	40	25	205	100	120	SCA 4/1.5/1
100	40	40	205	100	120	SCA 4/1.5/1.5
100	50	25	230	125	125	SCA 4/2/1
100	50	40	230	125	125	SCA 4/2/1.5
100	100	40	300	150	205	SCA 4/4/1.5
150	40	25	240	125	145	SCA 6/1.5/1
150	50	25	240	125	150	SCA 6/2/1
150	80	25	255	125	165	SCA 6/3/1
150	100	25	305	150	205	SCA 6/4/1
150	40	40	240	125	145	SCA 6/1.5/1.5
150	50	40	240	125	150	SCA 6/2/1.5
150	40	50	255	125	145	SCA 6/1.5/2
150	50	50	255	125	150	SCA 6/2/2
225	40	25	330	150	185	SCA 9/1.5/1
225	50	25	330	150	190	SCA 9/2/1
225	40	40	330	150	185	SCA 9/1.5/1.5
225	50	40	330	150	190	SCA 9/2/1.5
225	80	40	405	230	205	SCA 9/3/1.5
225	100	40	405	230	240	SCA 9/4/1
225	150	40	405	230	265	SCA 9/6/1.5
225	50	50	355	150	190	SCA 9/2/2
300	40	25	380	190	220	SCA 12/1.5/1
300	40	40	380	190	220	SCA 12/1.5/1.5
300	50	40	380	190	230	SCA 12/2/1.5
300	100	40	430	230	280	SCA 12/4/1.5
300	150	40	430	230	305	SCA 12/6/1.5
300	50	50	405	190	230	SCA 12/2/2
300	80	40	430	230	240	SCA 12/3/1.5
300	80	50	430	230	240	SCA 12/3/2
300	100	50	430	230	280	SCA 12/4/2
300	150	50	430	230	305	SCA 12/6/2
300	100	100	430	230	275	SCA 12/4/4
450	50	25	450	275	300	SCA 18/2/1
450	150	50	550	300	380	SCA 18/6/2
450	225	50	760	380	405	SCA 18/9/2
600	150	50	660	300	450	SCA 24/6/2
600	225	50	700	350	470	SCA 24/9/2
600	300	100	800	400	525	SCA 24/12/4

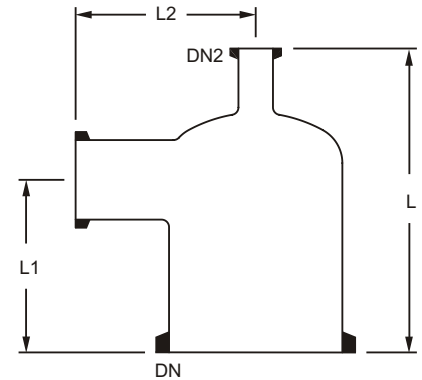
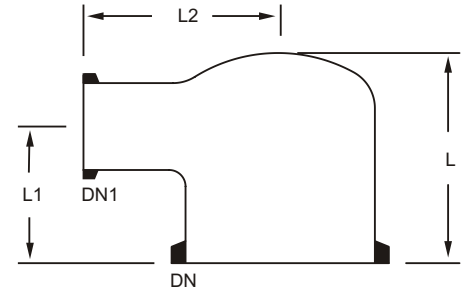

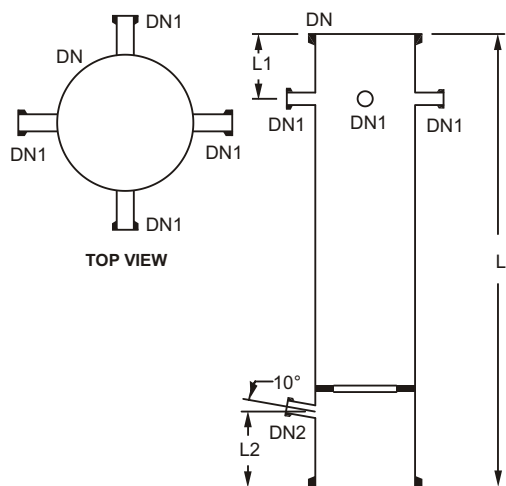

COLUMN SECTION FOR LIQUID RE-DISTRIBUTION TRAYS

These special column sections are designed specifically for use with type liquid distribution trays (SFVE). They are supplied complete with optional thermometer branch. (See Cat. Ref. SCSTV for thermometer branch in column section.) Column is supplied with 3 sides holding a liquid distribution tray on top if the column at required distance.

DN	L	DN1	DN2	L1	L2	CAT. REF.	CAT. REF.
225	1500	40	25	110	125	SCSV9/1500	SCSTV9/1500
300	1500	40	25	160	125	SCSV12/1500	SCSTV12/1500
450	1500	40	25	150	125	SCSV18/1500	SCSTV18/1500
600	1500	40	25	220	125	SCSV24/1500	SCSTV24/1500

Cat. Ref. SCSV refers without thermometer branch.

Cat. Ref. SCSTV refers out thermometer branch.

LIQUID RE-DISTRIBUTION TRAYS

When used below a PTFE re-distributor, these glass/PTFE distribution trays ensure return of the liquid from the edge of the column and optimum re-distribution. They are installed in type SCSV or SCSTV column sections.

The complete item comprises the tray, support fingers and coupling and gasket to fix them into position.

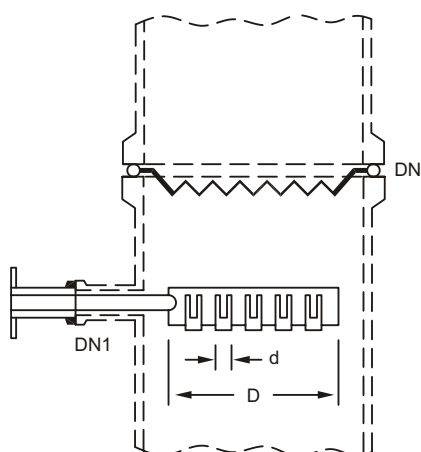

DN	DN1	D	d	NUMBER of d	CAT. REF.
225	40	165	18	9	SFV 9
300	40	230	18	19	SFV 12
450	40	345	28	19	SFV 18
600	40	470	28	31	SFV 24

DISTRIBUTION TRAYS FOR LIQUID FEED

These glass/PTFE distribution trays together with type SFVP inlet feed pipes detailed below are installed via type SFVZ feed sections. They provide an even initial distribution over the column cross-section. The complete item comprises the trays, support fingers and coupling and gaskets to fix them into position.

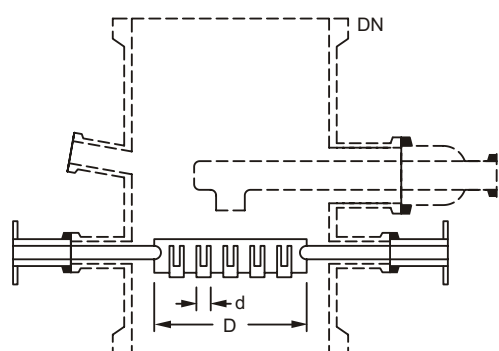

DN	D	d	NUMBER OF d	CAT. REF.
225	165	18	8	SFVE 9
300	230	18	18	SFVE 12
450	345	28	18	SFVE 18
600	468	28	30	SFVE 24

INLET FEED PIPES FOR FEED SECTIONS

These feed pipes are designed specifically for use with the distribution trays.

DN	DN1	DN2	L1	L2	CAT. REF.
225	80	25	210	150	SFVP 9
300	80	25	240	150	SFVP 12
450	80	40	320	150	SFVP 18
600	150	50	450	200	SFVP 24

FEED SECTION FOR DISTRIBUTION TRAYS

Distribution plates for liquid feed together with inlet feed pipes, are installed via these special feed sections.

They are basically unequal tee pieces with three additional branches for installing the distribution plates and a branch for a thermometer.

DN	DN1	DN2		L	L1	L2	L3	L4	CAT. REF.
		x 3 No.	DN3						
225	80	25	25	300	210	110	150	150	SFVZ 9
300	80	25	25	400	240	160	210	200	SFVZ 12
450	80	40	25	400	320	135	210	200	SFVZ 18
600	150	50	25	600	450	220	300	300	SFVZ 24

REFLUX SEPARATORS - MANUALLY OPERATED

In these units, the reflux is adjusted by means of a valve on the outlet connection.

When the valve is fully opened the divider is set to total distillate off-take,

Since the reflux pipe is higher than the outlet connection, by regulating the valve, the reflux ratio can be continuous adjusted up to total.

DN	DN1	L	L1	L2	CAT. REF.
80	25	190	115	82	SRDA3
100	25	255	145	95	SRDA4
150	25	255	145	100	SRDA6
225	25	380	165	115	SRDA9
300	25	380	165	110	SRDA12
450	40	610	275	150	SRDA18

FLOW DATA FOR SRDA

MINIMUM SPACE CROSS-SECTION FOR VAPOURS (cm ²)	MAXIMUM DISTILLATE VOLUME IN RELATION TO WATER AT 20°C (l/h)	CAT. REF
10	300	SRDA 3
20	475	SRDA 4
40	700	SRDA 6
150	900	SRDA 9
170	1100	SRDA 12
670	1500	SRDA 18

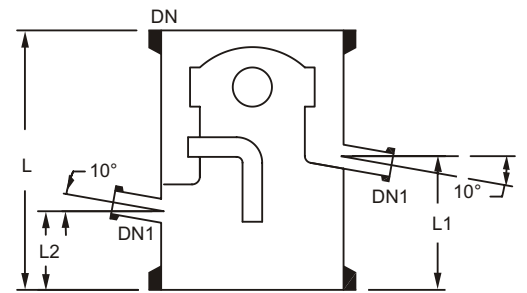
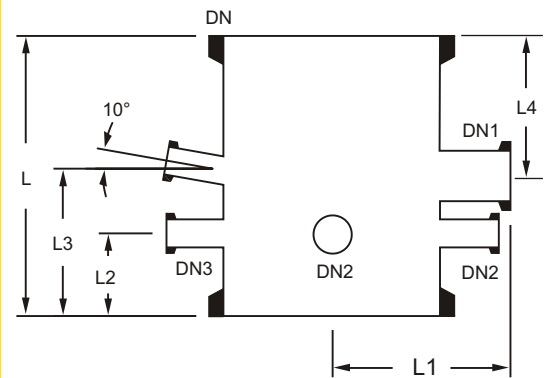
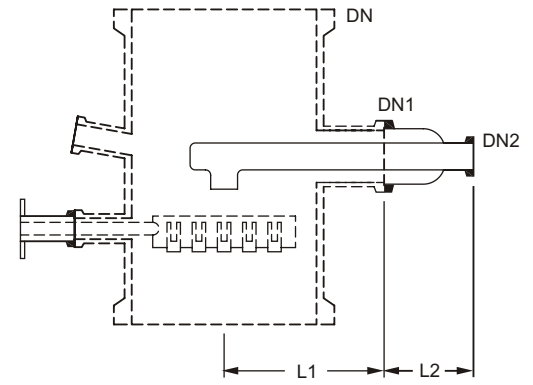

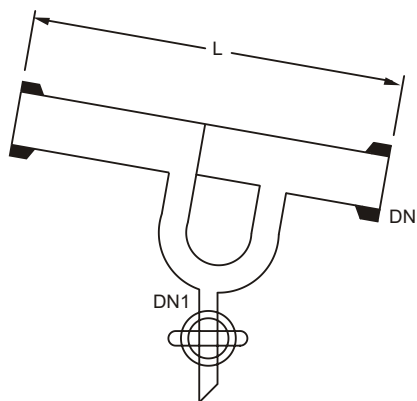

LIQUID SEALS

Liquid seals are fitted on the off-take branch of reflux separators to prevent vapours passing directly to the after-cooler and receivers.

DN	DN1	L	CAT. REF.
25	25	160	SLS 1
40	25	315	SLS 1.5

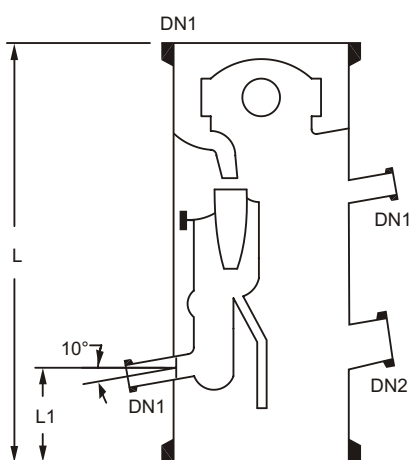

REFLUX SEPARATORS - AUTOMATICALLY OPERATED (MAGNETICALLY)

In application where there is need for the reflux to be at a fixed value, then it is advisable to fit an electro-magnetically or pneumatically operated reflux separators in conjunction with timer. Automatically controlled reflux separators are detailed below.

This type of reflux separator uses a swinging funnel mechanism. The funnel, which has a soft iron core sealed into it, is operated magnetically from outside the column so that the condensate can be removed from the column and reflux returned to the column in correct ratio. Activation of the electro-magnet moves the funnel into the off-take position. The electro-magnet (shown dotted) and timer should be ordered separately. Main hole (DN2) is provided for SRHM 9 and above sizes.

DN	DN1	DN2	L	L1	CAT. REF.
80	25	-	380	75	SRHM 3
100	25	100	455	90	SRHM 4
150	25	100	455	90	SRHM 6
225	25	100	560	115	SRHM 9
300	25	100	685	125	SRHM 12
450	40	100	915	165	SRHM 18

FLOW DATA FOR SRHM

MINIMUM SPACE CROSS-SECTION FOR VAPOURS (cm ²)	MAXIMUM DISTILLATE VOLUME IN RELATION TO WATER AT 20°C (l/h)	CAT. REF
10	90	SRHM 3
20	180	SRHM 4
40	300	SRHM 6
150	525	SRHM 9
170	675	SRHM 12
670	1350	SRHM 18

ELECTRO – MAGNET

Electro-magnets are used to operate magnetically operated Reflux dividers. When 'ON' the magnet attracts the swinging funnel of the reflux divider so that distillate can be taken off.

Electro-magnets are to be mounted outside OFF the glass column, just near to the reflux divider, with the help of adjustable fittings. These are designed to use with Timers to maintain correct ratio between 'OFF and 'ON' timings of its activation.

Electro-magnets work on 220V DC power supply, for which a output socket is provided in the Timers.

CAT. REF.	TYPE
SRPM	Non-flameproof
SRPF	Flameproof

TIMERS

Timers are designed to use with Electro-magnets to provide a correct ratio of reflux and distillate when operating a Magnetically operated reflux divider.

Two independent knobs are provided for time settings of Reflux and Off-take. During 'Off-take' it activates the electro-magnet, which attracts the swinging funnel of reflux divider, and distillation comes out. Both periods can be set accurately within a range of 0-50 seconds.

Timers work on a power supply of 230V, 50Hz.

CAT. REF.	TYPE
SQRT	Non-flameproof
SQRF	Flameproof

